

# Fitting Guide

# HD DECK® 150

It is recommended that *HD Deck® 150* is installed as per this fitting guide, **paying special attention to steps 1 & 7.**

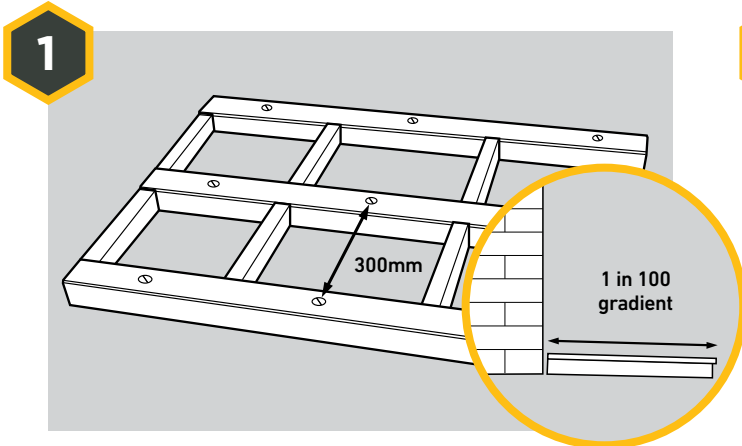
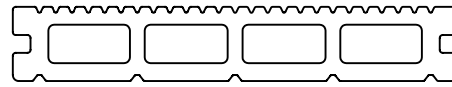

We recommend using treated 47x100mm timber joists and building in a gradual gradient of at least **1 in 100** (1%) that runs away from any adjoining buildings. Boards should run lengthways down this gradient to help water naturally disperse.

**IMPORTANT:** Spacing between the joists should be no greater than **300mm** between each joist.

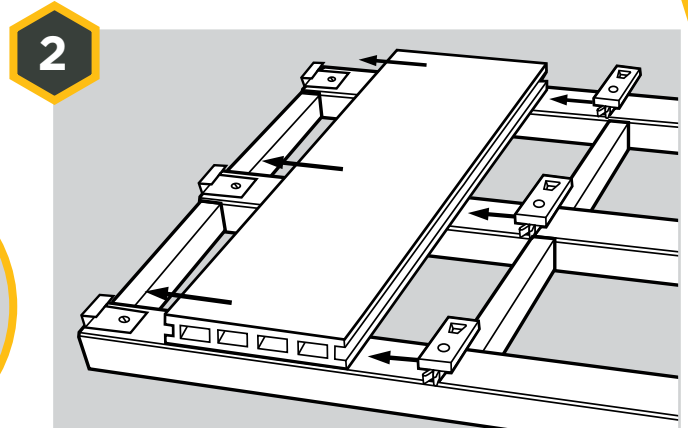

Place the first piece of decking on the timber frame with the decking running perpendicular to the joists. The first piece of deck may be secured with starter clips. **Do not screw or nail through HD Deck® 150**, use one Universal Clip and screw on every joist.

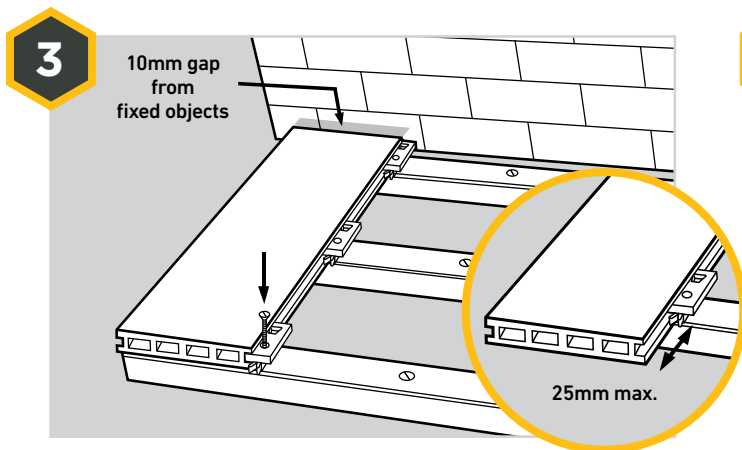

To secure the first board, use one Universal Clip and screw on every joist. Take a screw, place in the hole located in the Universal Clip and screw into the wooden joist. **Do not tighten at this stage.** Make sure the boards do not overhang the joist at the edge by **more than 25mm** and a **10mm expansion gap** should be left between the wall or other fixed objects surrounding the deck.

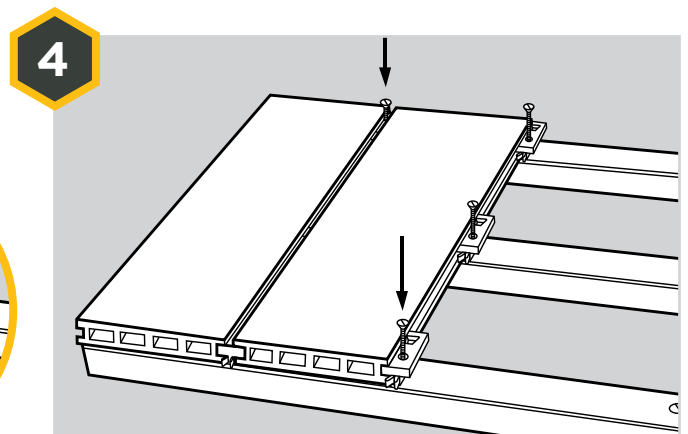

Take the next piece of deck and securely push into the Universal Clips. Now nip the screw to secure the Universal Clip against the board. **Do not over tighten.** Now repeat steps 3 and 4 to cover the deck, using one Universal Clip and screw on every joist.

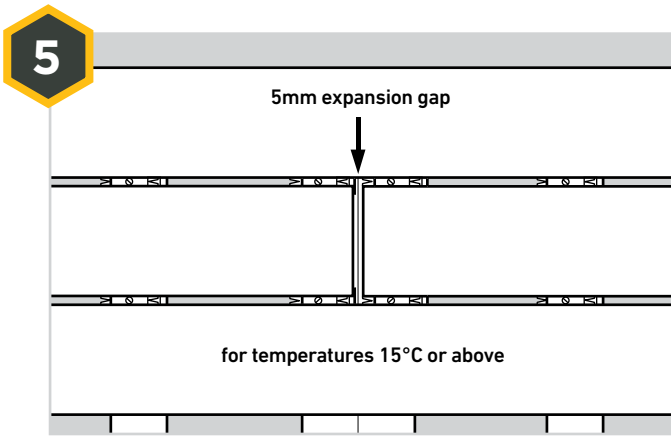

**IMPORTANT:** Do not allow deck boards to meet at the ends. When installing in temperatures of:

- 15°C or above allow a **5mm gap for expansion.**
- Between 10-15°C allow a **6mm gap for expansion.**
- Between 5-10°C allow a **7mm gap for expansion.**

Do not install in temperatures below 5°C. Joins should only occur over double joists with a clip securing each end.

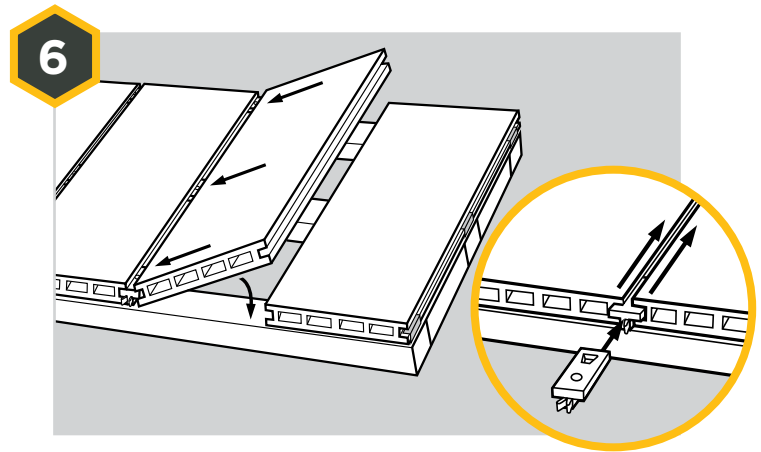

To fit the final boards, first measure the width of the final two boards to find out where the outer edge of the final board will lie. Using these marks, fit starter clips and slot the final board into place. Now insert the penultimate board, slide down the required number of Universal Clips and screw these into place.

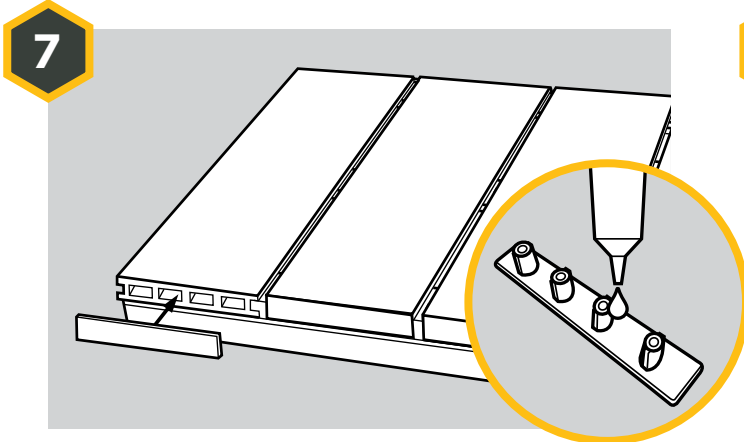

If using end caps, apply a high quality grab adhesive to the end caps to secure for extra adhesion. Wipe away any excess from the edge of the cap.

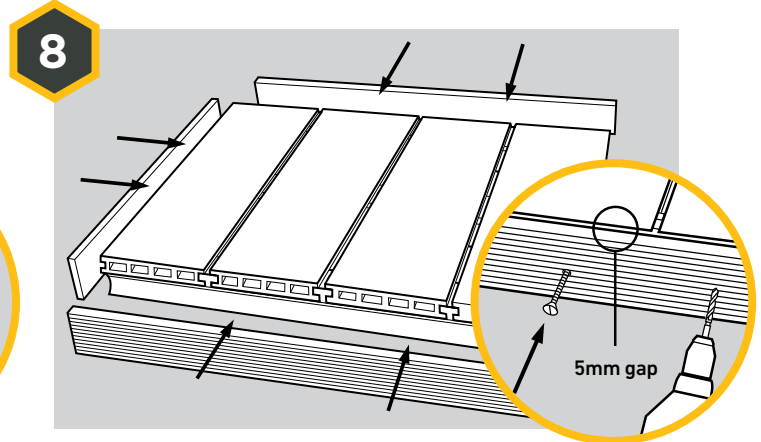

If using fascia, drill pilot holes with counterbore through the fascia at 200-300mm intervals. According to ambient temperature allow a **5-7mm gap** between end of deck board and the fascia. Screw fascia to the joist. Always screw fascia to the joist at a 90° degree angle.

## Composite Prime Care & Maintenance Guidelines

### Care Guidelines

Even though HD Deck® 150 is a low maintenance product periodic cleaning is recommended, even if your HD Deck appears clean it is important to prevent the build-up of pollen and debris that can cause mold growth.

It is recommended that furniture placed on HD Deck® 150 is fitted with rubber or felt feet to prevent unnecessary scrapes.

### Weathering

During the first 6 - 12 months the colour pigments will stabilize, during this time fading may occur before weathering naturally.

### Cleaning Guidelines

Domestic pressure washers maybe used with caution in conjunction with the spray nozzle. Pressure washers can be used to remove stains, ground-in dirt and chalk. Keep a **distance of at least 1ft between the nozzle and the deck** to prevent damage to the deck.

If unsure about the product being used to clean/remove stains from your deck, it is always recommended that you test a small area in an inconspicuous place to determine if the cleaning product will cause any unwanted discolouration.

### Dirt, debris and watermarks

Clean the decking to remove dirt or debris by using soap, hot water and a stiff bristle. Rinse thoroughly.

### Mold and Mildew

Use an organic patio cleaner such as Algon or a sodium percarbonate oxygen activated bleach. Ensure all detergent is washed off after use.

### Chalk Markings

Scrubbing the area with hot soapy water may dislodge some of the chalk. Rinse thoroughly.

### Ice and Snow

Calcium chloride or rock salt, available in many home centers, will melt ice on decking. Rinse thoroughly when practical.

### Rust Stains, Ground-in Dirt and Grime

Use a cleaning product containing oxalic or phosphoric acid base to lighten or remove the rust or dirt. Product may need to sit on stain 10-15 minutes. Rinse thoroughly.

### Oil and Grease Stains

Scrub in a household-degreasing agent as soon as the stain occurs. Rinse thoroughly with warm water. Or use Abzorbit grease and oil stain remover.

### Berries and Wine Stains

Mix an eco friendly sodium percarbonate bleach in hot water label. Scrub the stain lightly and immediately rinse the area thoroughly. Note: Using too much bleach may cause lightening

Images and drawings are for illustrative purposes only. HD Deck® 150 may be laid in a variety of patterns, we recommend that you draw out how you would like your deck to appear, making notes of joins and joists before starting the installation. For elevated decks greater than 600mm (0.6m) in height we recommend using a professional installer. When cutting, always saw the board face up with a fine-toothed blade to prevent furring the face edge.

Don't forget to register your warranty, within 45 days of purchase, at [www.composite-prime.com/register-warranty](http://www.composite-prime.com/register-warranty).