

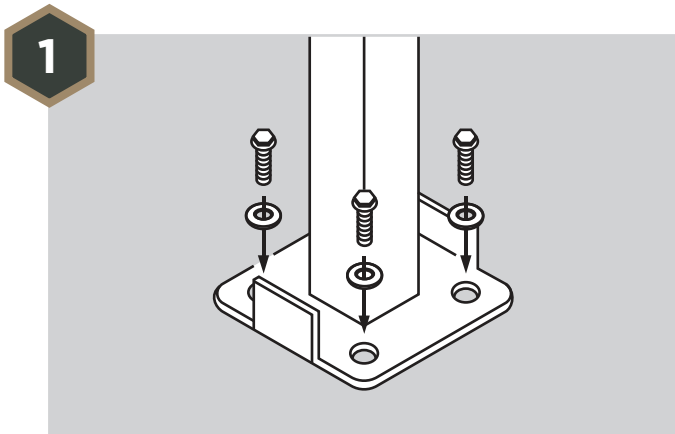

Fitting Guide

Both the balustrade and post kits can have sharp or pointed edges. It is recommended that protective gloves are worn as much as possible during the installation process.



Position your steel post mounts **without** fixing, to check measurements. Take care that these do not fall over if unsupported. You can use bottom rails (sizes shown on your checklist) to check these posts are spaced correctly. When happy with the positioning mark the 4 holes and bolt the steel posts using bolts or screws/washers provided or selected by you/your contractor.

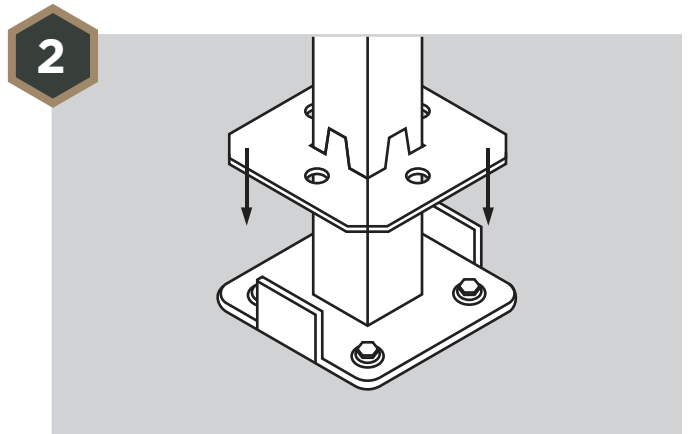

Slide one steel spacer plate, with the 4 lugs facing upwards, over each post mount until it rests on the weld near the bottom.

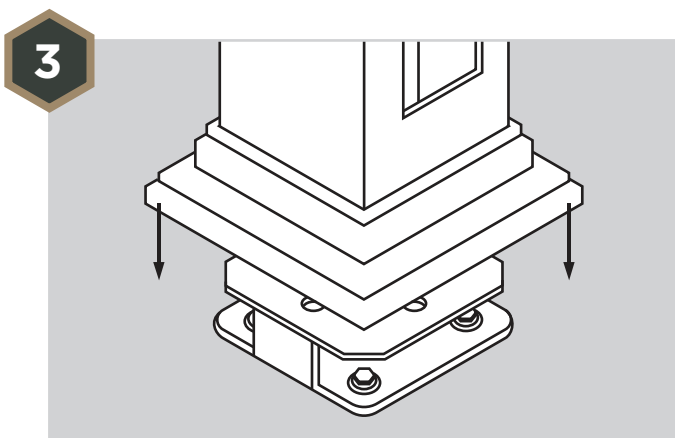

Slide uPVC posts over each steel post mount after adding the post skirting trim to the bottom of each PVC post. Check that these are correctly positioned, e.g. corner, line or end post configuration.

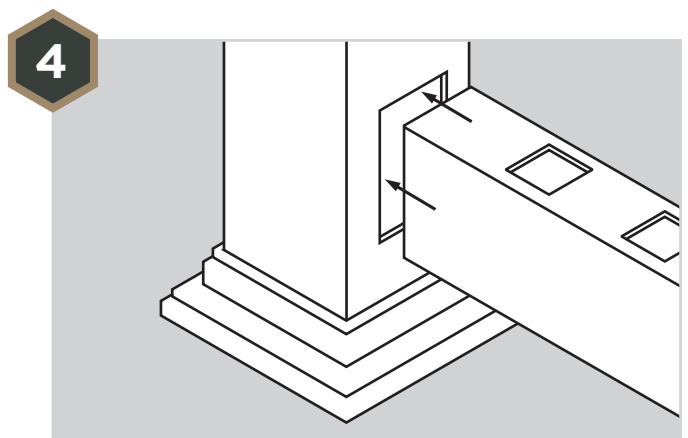

Insert bottom rails into the uPVC posts. It is easier if you lift one post up over the spacer plate so the post can be moved more freely.

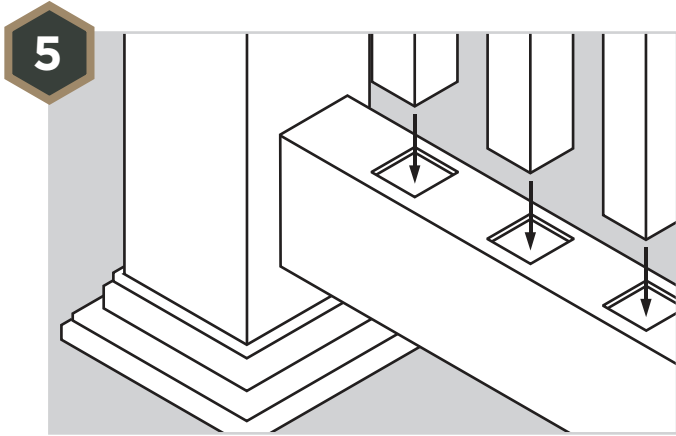

When bottom rails are in place, insert all spindles.

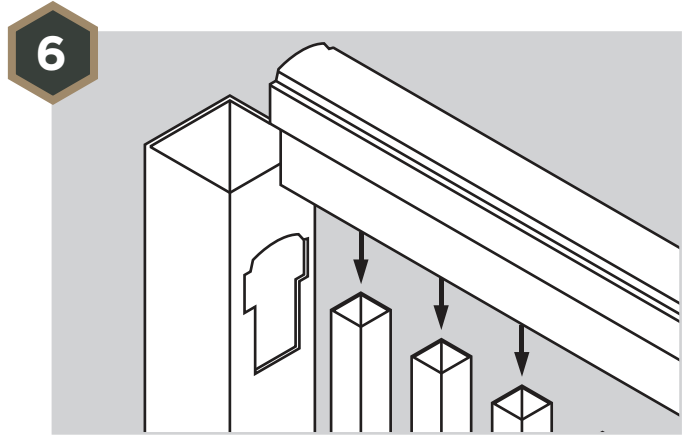

Add top rails to top of spindles.

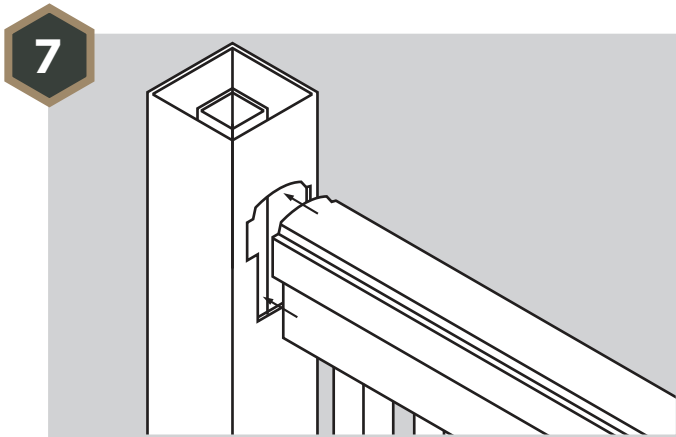

Then insert top rails into vinyl posts.

NOTE: If you have shaped top rail and a corner post one of the rails will need to have a notch cut out so they do not obstruct one another inside the PVC post. A 25mm notch is recommended from the corner of one handrail, do not oversize the notch as it may then be visible outside the PVC post.

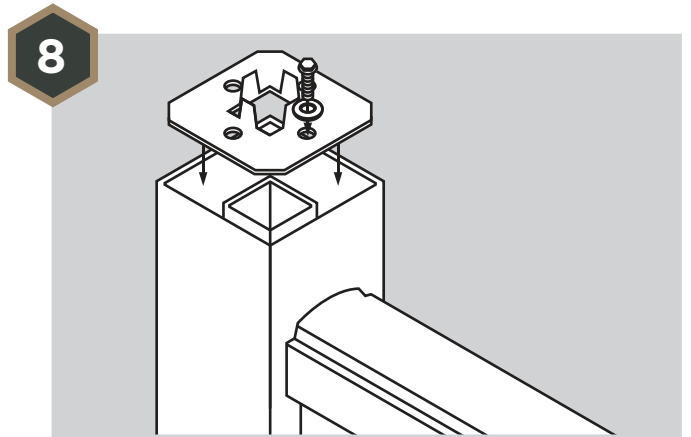

When all top rails are in place, insert the second steel spacer plate down onto each steel post mount so that it rests on top of the inserted top rails.

Put a screw through both holes in the spacer plate to secure the top rails in position. Ensure your spindles are evenly spaced and upright before securing top rails. You may ensure the top spacer plates are secured more tightly to the steel post by driving a screw between the spacer and the steel post. This will "lock" it to the steel preventing the rails section being pulled upwards.

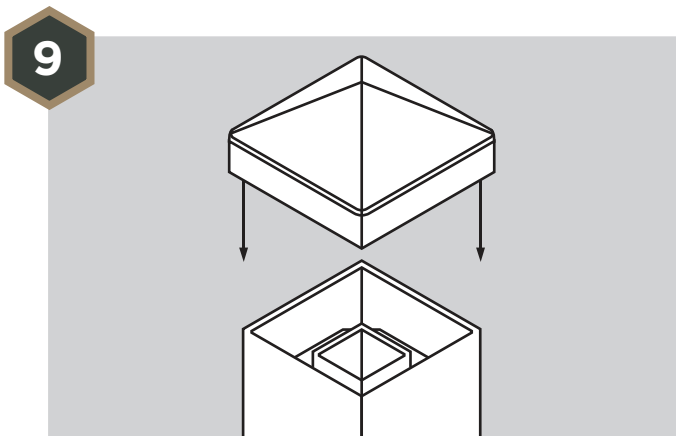

Now you can glue/silicone on your post caps and clean your rails if necessary, with soapy water. Stubborn marks can be removed with white spirit, or use of a light uPVC cream cleaner.

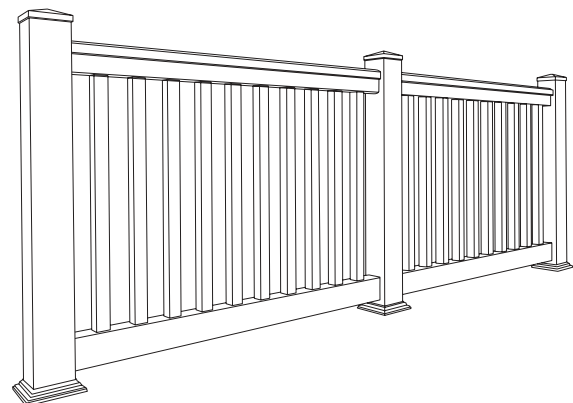

NOTE: Composite Prime do not provide fixings for the steel post mount as the type of substrate varies greatly. You must purchase suitable fixings before proceeding.