

Please read the **Important Notes** on reverse before starting.

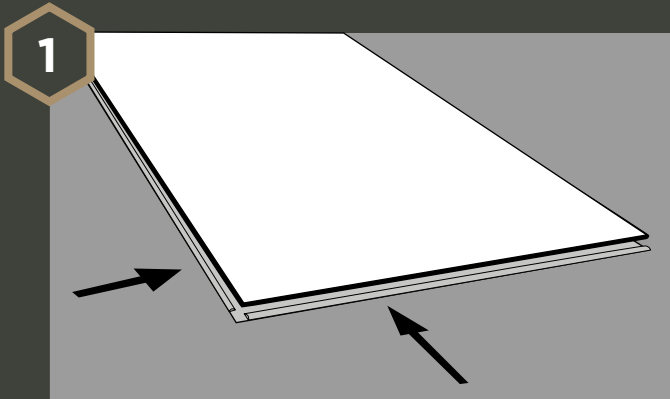

Once subfloor is fully cleaned and prepared, begin with laying planks left to right for first row. Place first plank so grooved edge is facing towards you.

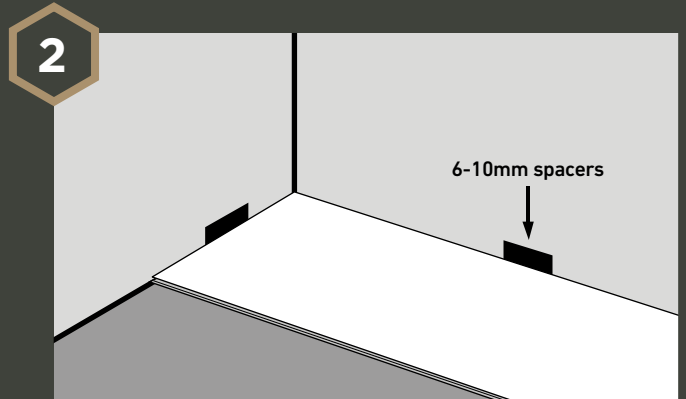

Insert 6mm spacers (minimum) between the wall and plank. Please consider that the expansion rate is 0.1% average. Lay the next board in the row interlocking with the first end-to-end and click to lock together. These should be the same height. Ensure alignment, then continue in same method.

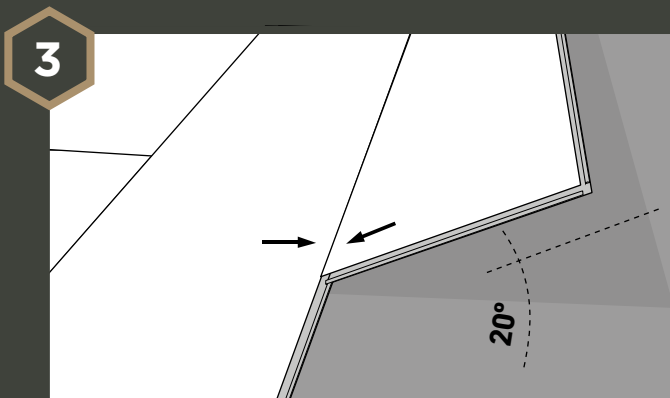

Beginning the next row, use remainder of cut plank from last piece of first row, provided piece is minimum 300mm. Otherwise cut a new plank to begin this row, ensuring joints are at least 180mm apart. Use the remainder of cut planks for ends of rows to begin subsequent rows whenever possible.

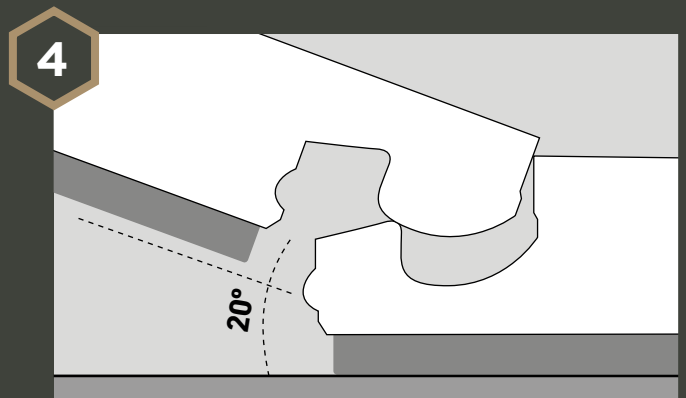

Click together the long sides of the new plank and the one in the previous row, placing the board tightly to the short end of the previous plank in this row with an angle of 20°. Drop the plank, and push to lock firmly together. These should be the same height if laid properly. Ensure both are perfectly aligned.

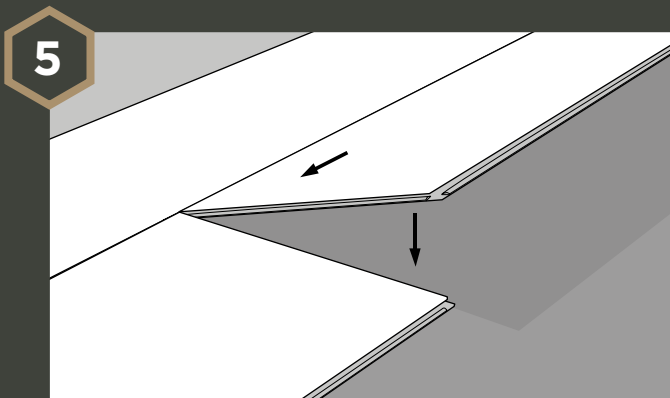

Slide board into position and drop into place.

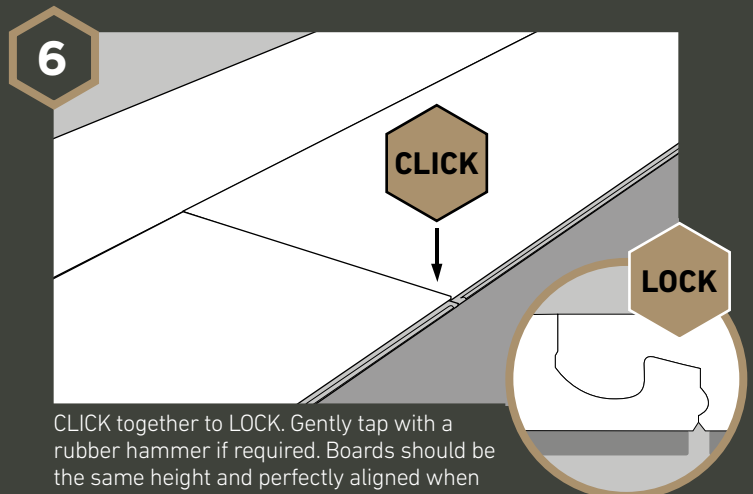

CLICK together to LOCK. Gently tap with a rubber hammer if required. Boards should be the same height and perfectly aligned when locked properly. If you are not using existing beading boards, expansion gaps can be finished with matching Touchstone beading that can be attached to the walls.