

Please read the **Important Notes** on reverse before starting. Incorrect installation will void the warranty.

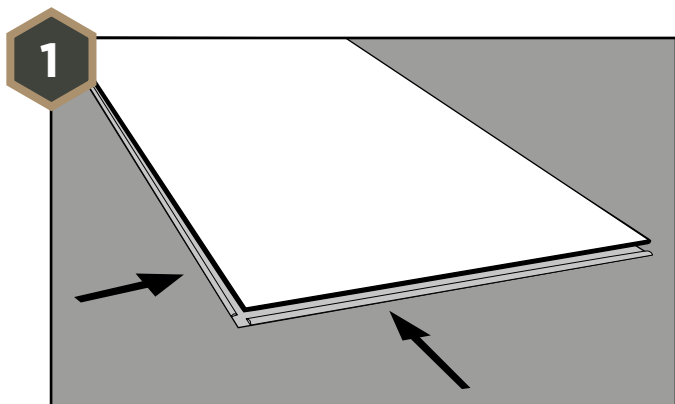

Check your sub-floor is clean and solid before installation, do not use any alternative underlay. Begin with laying planks left to right for first row. Place first plank so grooved edge is facing towards you.

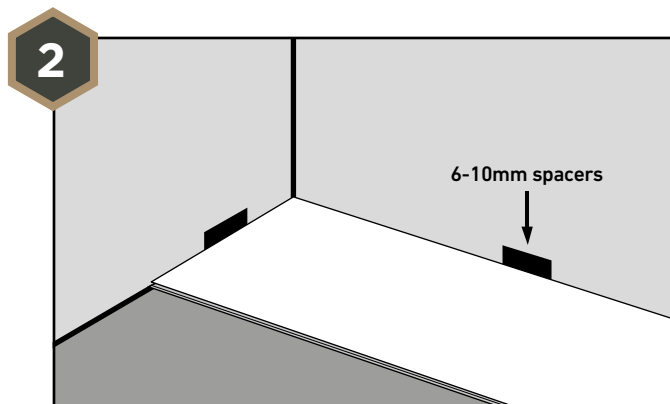

Insert 6mm spacers (minimum) between the wall and plank. Please consider that the expansion rate is 0.1% average. Lay the next board in the row interlocking with the first end-to-end and click to lock together. These should be the same height. Ensure alignment, then continue in same method.

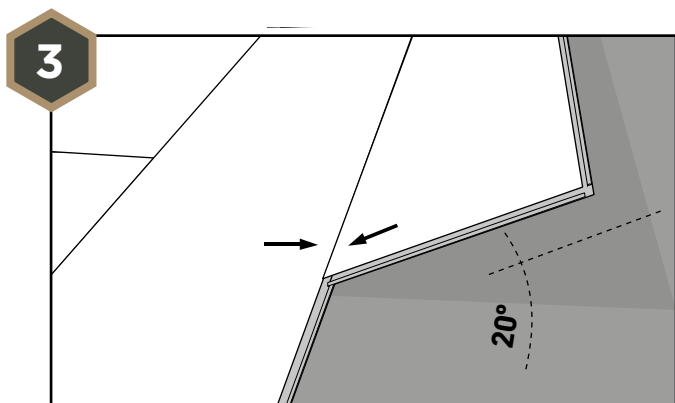

Beginning the next row, use remainder of cut plank from last piece of first row, provided piece is minimum 300mm. Otherwise cut a new plank to begin this row, ensuring joints are at least 180mm apart. Use the remainder of cut planks for ends of rows to begin subsequent rows whenever possible.

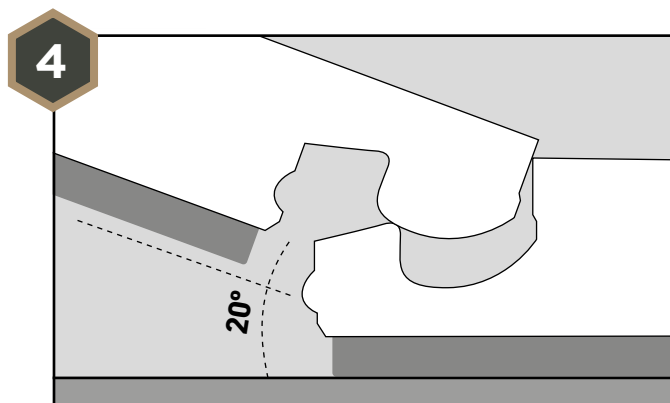

Click together the long sides of the new plank and the one in the previous row, placing the board tightly to the short end of the previous plank in this row with an angle of 20°. Drop the plank, and push to lock firmly together. These should be the same height if laid properly. Ensure both are perfectly aligned.

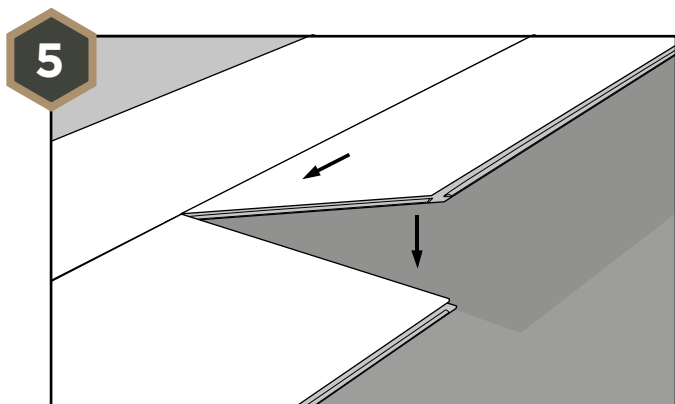

Slide board into position and drop into place.

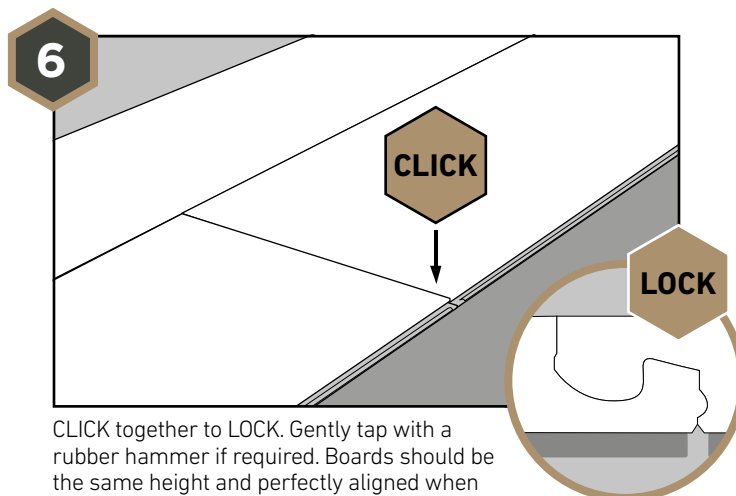

CLICK together to LOCK. Gently tap with a rubber hammer if required. Boards should be the same height and perfectly aligned when locked properly. If you are not using existing beading boards, expansion gaps can be finished with matching Touchstone trim that can be attached to the walls.

Important Notes

Estimating

Check you have enough floor product to complete your flooring allowing for 10% wastage for cutting etc. This also should allow for some spare after project complete for any future repairs. Maximum room size 15m x 15m.

Climate

Open packs in the room that you are installing Touchstone Flooring, leave for 24 hours for the flooring to acclimatise to the rooms intended native temperature and conditions.

Sub-flooring Preparation

Check your sub-floor before installation. It must be dry and clean. Check that the surface is flat – within 3mm over a 3 metre span. If you have a greater variation than this, then a self-leveling compound should be used. Do not use any alternative underlay.

If installing on a wooden sub-floor, ensure there are no signs of mold or insects. The moisture content of the wood must not exceed 10%. Nail or screw down any loose parts to make level. If using leveling boards, fix with an appropriate glue or with screws every 30cm. Make sure there is proper ventilation under planks (minimum 4 cm² total ventilation openings per m² of floor).

Moisture

The moisture content of the sub-floor must be less than 2,5%CM / 75%RH (cement screed) or less than 0,5%CM / 50%RH (anhydrite screed - sub-floor). In the case of floor heating, results must be respectively 1,5%CM / 60%RH and 0,3%CM / 40%RH. Always measure, record and keep your moisture content results. New cement floors must dry at least 1 week per 1cm thickness up to 4cm. Thicknesses over 4cm require twice as much drying time.

Floating Floor

Touchstone is designed to be installed as a floating floor and allowance of 6mm minimum must be allowed around edge of room. Always run underneath kitchen cabinet kick boards. Note that if the room gets significant sun, allow minimum 10mm around edge.

Underfloor Heating

Touchstone can be installed over in-floor heating. Ensure the heating is evenly distributed and the floor temperature does not exceed 30°C. If only part of the floor has underfloor heating, the flooring over the heating must be separated from the unheated section using a dilation joint to accommodate for greater expansion and contraction.

Waterproof

Touchstone is a waterproof material, but that does not mean that water can not pass through joints etc. The sub-floor must not have moisture content any greater than 2% and if any leak/flood does occur, the floor should be uplifted to allow the area to fully dry. **Do not install directly under showers.** Touchstone Flooring is not to be used in any exterior situation.

Layout

To provide the best color blend, please ensure you open and install from 3-4 boxes at a time. Always try to lay the floor in the linear direction of the sun or main light source. Continuous flooring should not exceed 15 metres length and 10 metres width.

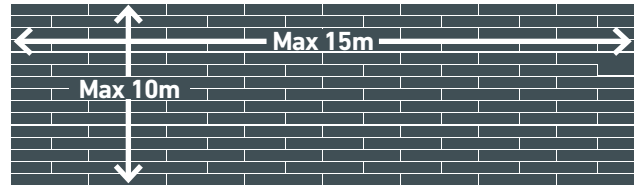

Perimeter Expansion Gap

Any greater spans than 10 metres in width must be broken up with an expansion joint. This gap should be finished with a metal threshold. Maximum room size 15m x 15m.

How to Disengage

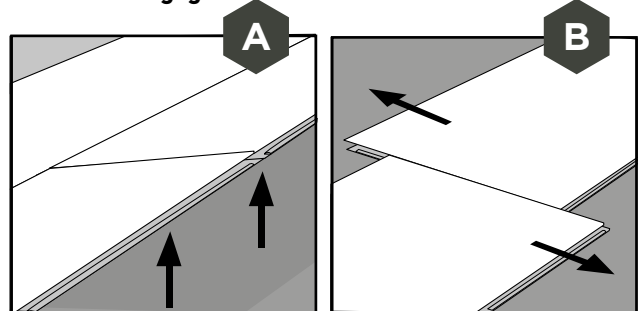

A Lift entire row of boards to 20° angle, disengage from main floor.

B Lay row flat and slide sections apart. If tight, gently tap with rubber hammer to fully disengage.

How to Cut Lengths

Simply score the board with a sharp utility knife and straight edge, then snap along the score for a clean break.

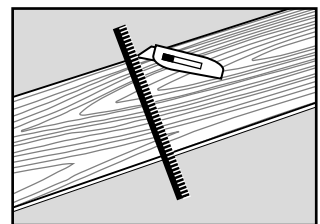

Composite Prime Care & Maintenance Guidelines

- Use soft bristle attachments
- Sweep and / or vacuum on regular basis
- Clean any spills immediately
- Use damp mop as needed to clean floor with mild PH neutral cleaner
- No oil or waxes
- Always use furniture feet protection – under chair and table legs etc.
- Never use abrasive cleaners on your floor
- Do not slide/drag heavy items across your floor
- It is always suggested to have a mat on entry ways etc.

Images and drawings are for illustrative purposes only. Tools needed: mallet, utility knife, saw with blades for plastic, mouth mask, safety glasses, tape measure, gloves, pencil.

Register your warranty, within 45 days of purchase, at www.composite-prime.com/register-warranty